

PB Salon Guard

Pure Beauty

The complete mobile extraction solution for salon hair treatments.

The BOFA Pure Beauty Salon Guard is a mobile fume extraction and filtration system that has been designed specifically to capture and remove the harmful fumes generated when carrying out hair treatments.

The health risks associated with Keratin based hair treatments have been well documented in the media but there are broader Health and Safety issues that must be considered when undertaking other hair treatments such as perming, colouring and bleaching.

Until now a practical solution for the removal of hazardous fumes has not been available. The Pure Beauty Salon Guard addresses Health & Safety concerns, requires no fixed installation, is cost effective and allows the stylist to work freely yet safely.

STANDARD FEATURES:

- Low noise level
- Fully portable
- Deep bed chemical filter
- Effective receptor capture hood

OPTIONAL FEATURE:

- VOC Sensing (Volatile Organic Compound)



PART NUMBERS			
Model	Voltage	Part No.	VOC Monitoring
Pure Beauty Salon Guard Powder Coated	230V	E2342A	A2003

REPLACEMENT FILTER	
Model	Chemical Filter
Pure Beauty Salon Guard	A1030256

TECHNICAL DATA	
	CE
Dimensions (HxWxD)	350 x 455 x 455mm
Cabinet Construction	Powder coated mild steel
Airflow / Pressure	380m³/hr / 30Mbar
Electronical Data	230v 1ph 50Hz FLC 1.9 Amps 280 Watts
Noise Level	< 60dBA
Weight	42kg

* At typical operating speed.

AIRFLOW THROUGH FILTERS

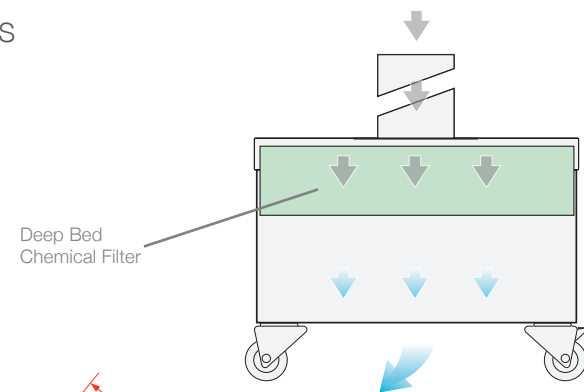

TECHNICAL SPECIFICATION

- 1 Extractor Arm - 100mm
- 2 On / Off Switch
- 3 Double Castors
- 4 Power Inlet
- 5 Filter Housing Latch
- 6 100mm Arm Inlet Connection
- 7 Exhaust Outlet
- 8 Arm Handle
- 9 Hood

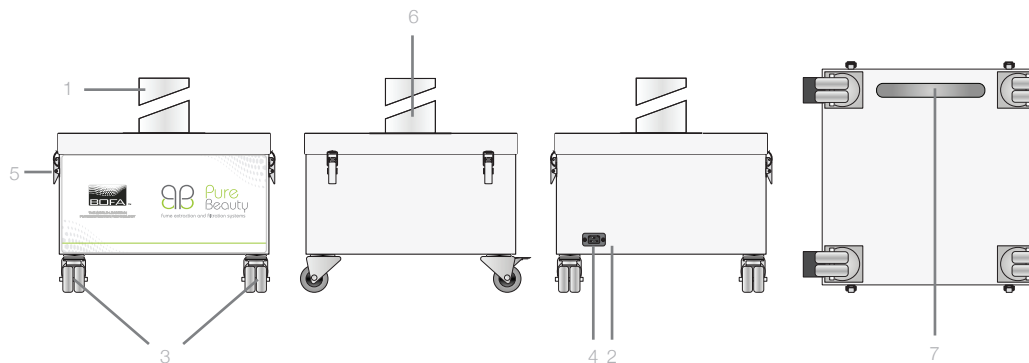
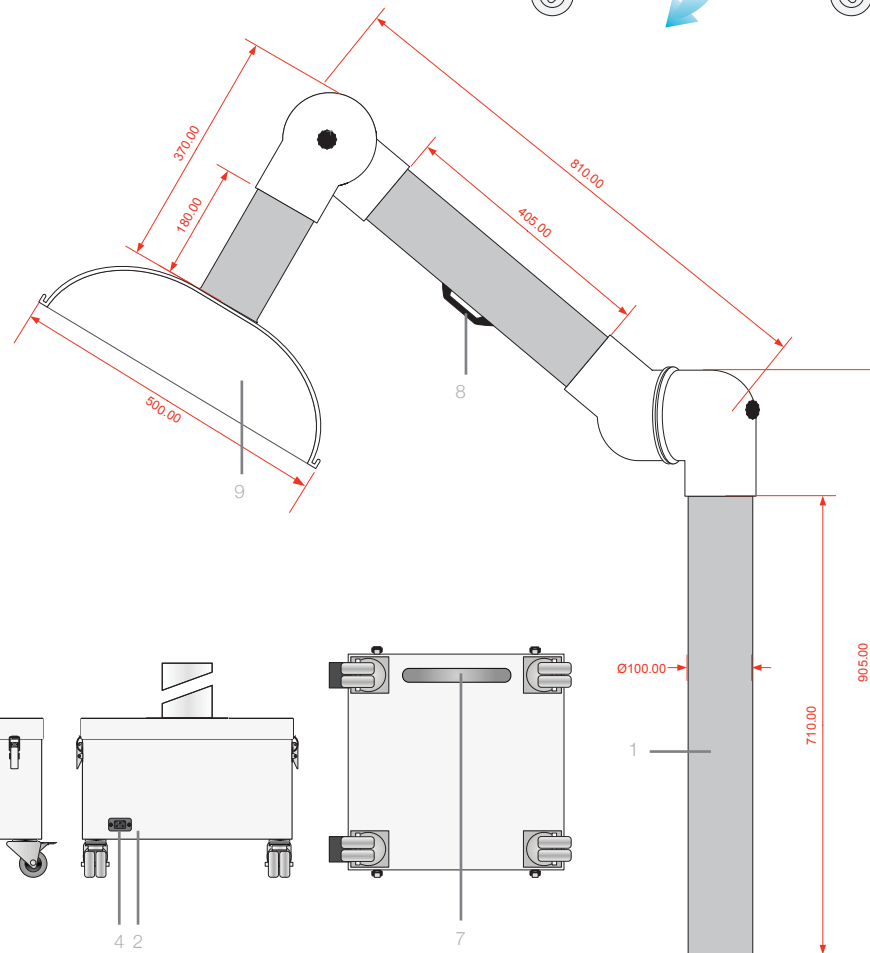

Other hose kits and filters are available. All of the above units are fitted with our standard filter combinations. For specific applications please call us for details. Replacement filters should always be ordered using the part number on the filters inside your extractor to ensure the correct filter is ordered. Datasheet correct at time of print.

Date:25/6/13 V:2



BOFA INTERNATIONAL LTD

Tel: +44 (0) 1202 699 444 Fax: +44 (0) 1202 699 446 Email: sales@bofa.co.uk Web: www.bofa.co.uk

BOFA AMERICAS, INC

Tel: (618) 205 5007 Fax: (866) 707 2632 Email: sales@bofaamericas.com Web: www.bofaamericas.com

