

"ALL IN ONE" NEW GENERATION SOLID STATE LASER MARKING UNIT

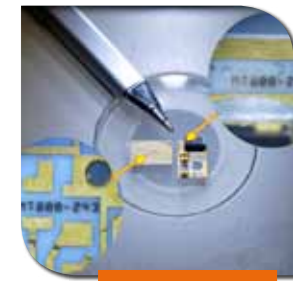

Micro - coding

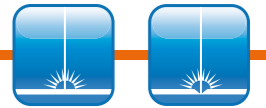

Labeling



Telecommunication



Deep engraving

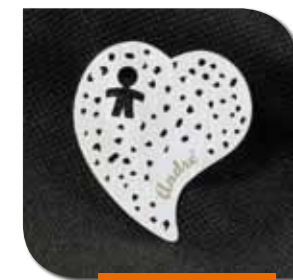

Jewellery

Model	Laser ³ 20 W
Wavelength (nm)	1064
Technology	multiple diode solid state laser
Max. power (typical) (W)	> 20
Pulse repetition frequency (kHz)	0 - 100
Max. Peak power (kW)	≈ 200
Max. Pulse energy (mJ)	1.5
Beam quality factor M ²	< 1.5
Spot diameter (µm)	f 100 = 25
	f 163 = 50
	f 254 = 90
	f 330 = 100
Working area (mm)	f 100 = 60 x 60
	f 163 = 110 x 110
	f 254 = 180 x 180
	f 330 = 220 x 220
Working distance (mm)	f 100 = 120
	f 163 = 210
	f 254 = 380
	f 330 = 440
Dynamic focus range (mm)	f 100 = 20
	f 163 = 50
	f 254 = 120
	f 330 = 180
Cooling	forced air-actively stabilized by TEC

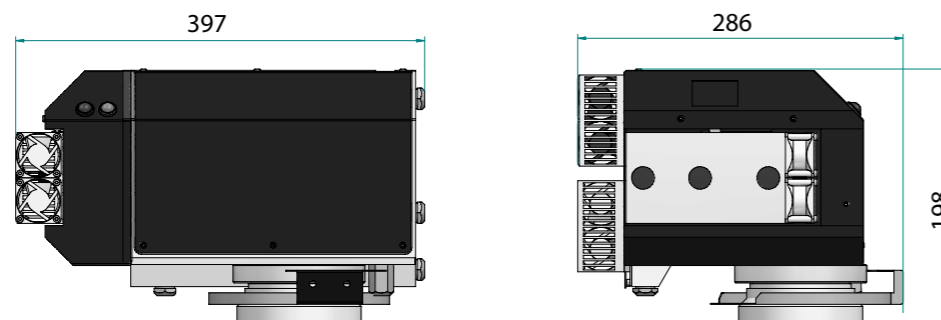

Features

- Compact size
- High reliability
- Long average life time
- Very low running costs
- The state of the art technology and performances
- Built-in full digital control electronics
- Air-cooled system
- Designed for OEM, customized solutions and to be integrated into automatic production lines
- Built-in remote diagnostics (internet service)
- Laser³ is a **Class 4** product

The product is CE marked.
Features and system requirements may change without notice.

10/2016



- The **OEM** line developed by **SEI Laser** is the latest range of products exploiting marking edge laser technology for industrial applications as well as **SEI Laser** know-how. It is the right solution for integrating laser technology into both on line and vertical systems.
- As well as HW and SW support, **SEI Laser** R&D works out solutions and applications to meet the requirements of a wide range of different industrial fields.
- Part of the **SEI Laser OEM** line, **Laser³** is a marking system with outstanding performance in terms of dynamics, acceleration on small sized work areas coupled with an extremely smallest spot size. Its main application fields are electronic, automotive, IDcard pharmaceutical, Food&Beverage, coding, traceability up to 220x220 mm.



Electric components



Mechanical components



Branding



ID card



Mechanical components

Laser³ is the right answer to the production flexibility required by the digital market nowadays and it is developed from **SEI Laser** to be easily integrated into production lines. **Laser³** is a laser marking system with solid

state laser technology operating in 1064 nm. The main feature of this latest laser solution, besides a peculiar optic frame of laser beam, is the fact that the laser cavity, scan head and full digital electronic control are incorporated in a unique small enclosure

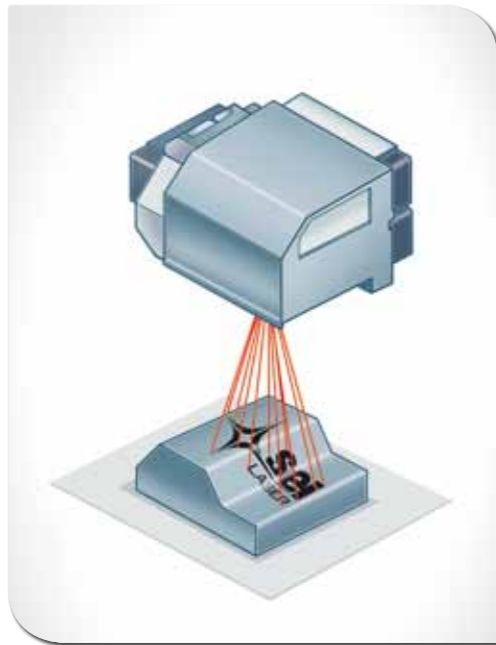

■ DYNAMIC FOCUS SHIFTING

To mark on different layers.

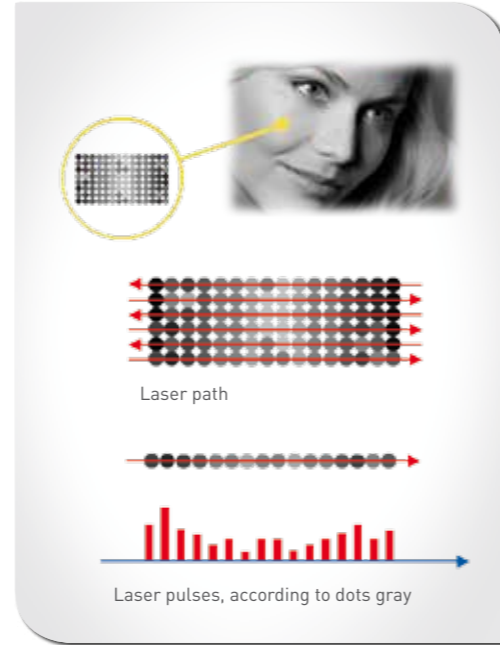

■ HI END GRAY-TONES CAPABILITY (LASER ENERGY MODE)

To perform remarkable photorealistic bitmaps at high marking speeds.

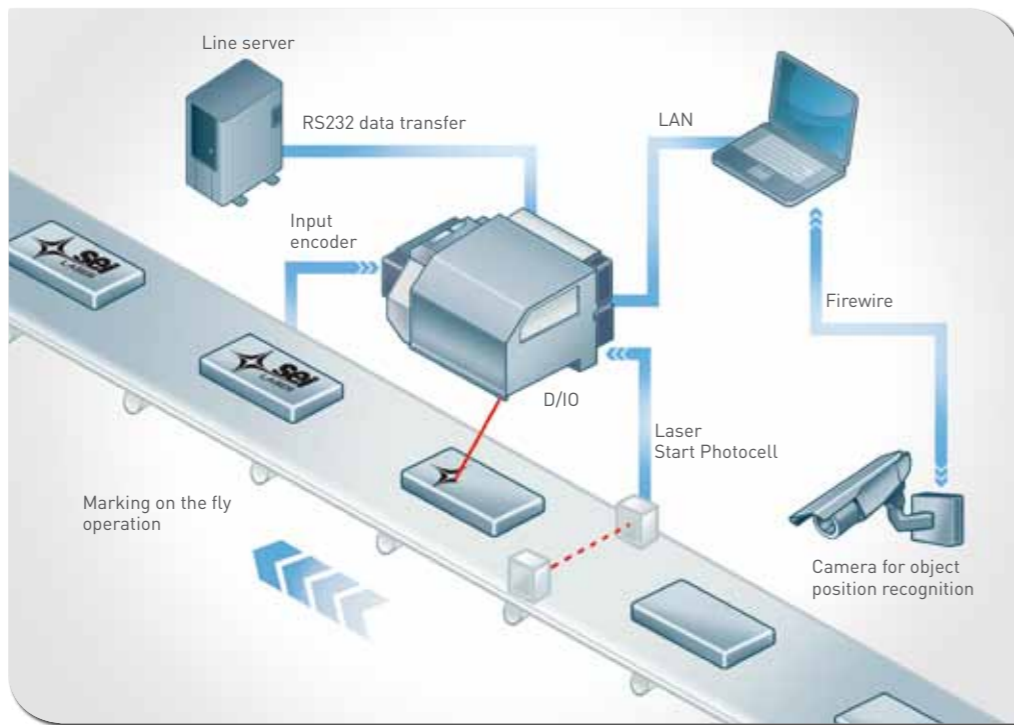

■ MARKING ON THE FLY

Enhance any production line with maximum productivity.

measuring 397x286x198 mm. **Laser³** can be controlled via PC through the user interface ICARO (Windows) or work in "stand alone" mode (without PC). ICARO currently monitors the status of the laser equipment laser on, emergency-

alarms, main parts working status, hour counter and many other parameters: synchronization and connections with production lines, automation, robots besides the normal machine options.

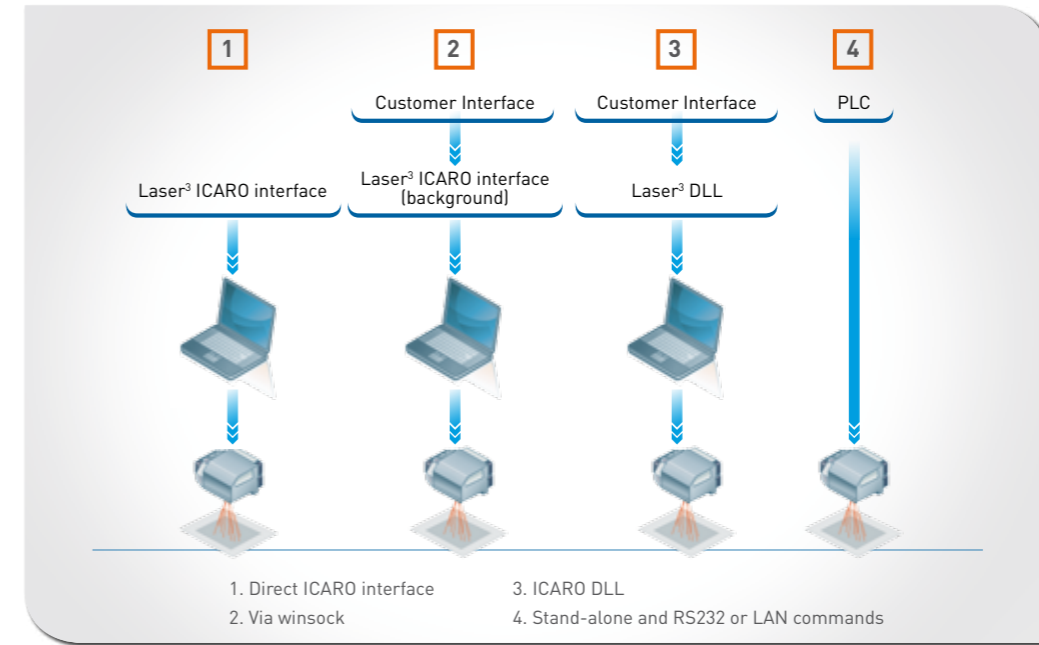

■ FLEXIBLE MULTIPLE SOFTWARE INTERFACES

From full ICARO interface software to stand alone management control.

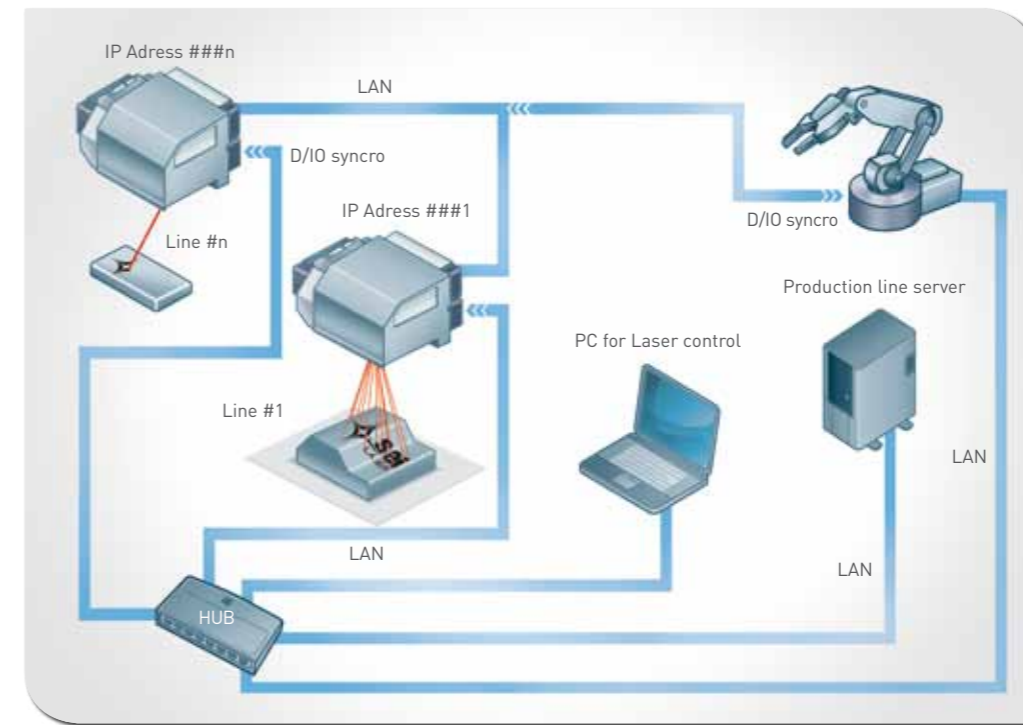

■ PLUG & PLAY HARDWARE

Easy and fast placement into existing or new automatic lines.



Night & Day

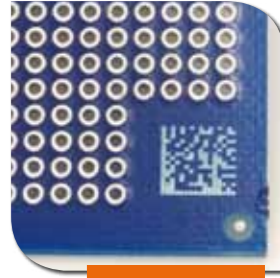

Electronic board



Pharmaceutical



Anti-counterfeiting



Electric components